



Rossmoyne Senior High School

WA Exams Practice Paper C, 2016

Question/Answer Booklet

**MATHEMATICS
APPLICATIONS
UNITS 3 AND 4**
Section Two:
Calculator-assumed

SOLUTIONS

Student Number: In figures

--	--	--	--	--	--	--	--

In words

Your name

Time allowed for this section

Reading time before commencing work: ten minutes
Working time for section: one hundred minutes

Materials required/recommended for this section

To be provided by the supervisor

This Question/Answer Booklet
Formula Sheet (retained from Section One)

To be provided by the candidate

Standard items: pens (blue/black preferred), pencils (including coloured), sharpener, correction fluid/tape, eraser, ruler, highlighters

Special items: drawing instruments, templates, notes on two unfolded sheets of A4 paper, and up to three calculators approved for use in the WACE examinations

Important note to candidates

No other items may be taken into the examination room. It is **your** responsibility to ensure that you do not have any unauthorised notes or other items of a non-personal nature in the examination room. If you have any unauthorised material with you, hand it to the supervisor **before** reading any further.

Structure of this paper

Section	Number of questions available	Number of questions to be answered	Working time (minutes)	Marks available	Percentage of exam
Section One: Calculator-free	7	7	50	52	35
Section Two: Calculator-assumed	12	12	100	100	65
Total				152	100

Instructions to candidates

1. The rules for the conduct of examinations are detailed in the school handbook. Sitting this examination implies that you agree to abide by these rules.
2. Write your answers in this Question/Answer Booklet.
3. You must be careful to confine your response to the specific question asked and to follow any instructions that are specified to a particular question.
4. Spare pages are included at the end of this booklet. They can be used for planning your responses and/or as additional space if required to continue an answer.
 - Planning: If you use the spare pages for planning, indicate this clearly at the top of the page.
 - Continuing an answer: If you need to use the space to continue an answer, indicate in the original answer space where the answer is continued, i.e. give the page number. Fill in the number of the question that you are continuing to answer at the top of the page.
5. **Show all your working clearly.** Your working should be in sufficient detail to allow your answers to be checked readily and for marks to be awarded for reasoning. Incorrect answers given without supporting reasoning cannot be allocated any marks. For any question or part question worth more than two marks, valid working or justification is required to receive full marks. If you repeat any question, ensure that you cancel the answer you do not wish to have marked.
6. It is recommended that you **do not use pencil**, except in diagrams.
7. The Formula Sheet is **not** to be handed in with your Question/Answer Booklet.

Section Two: Calculator-assumed

65% (100 Marks)

This section has **twelve (12)** questions. Answer **all** questions. Write your answers in the spaces provided.

Working time for this section is 100 minutes.

Question 8

(7 marks)

The tasks involved in a project, their immediate predecessors and duration, are shown below.

Task	A	B	C	D	E	F	G
Immediate predecessor	-	-	B	B	A, C	A, C	D, E
Duration (days)	11	8	7	10	6	12	9

- (a) Use the above information to complete the project network below. (3 marks)

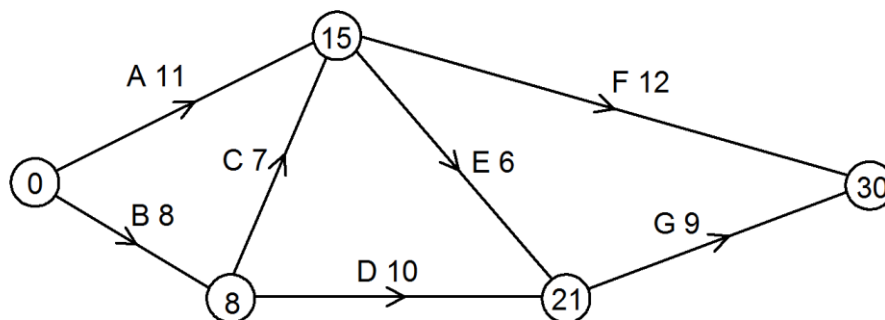

- (b) State the critical path and the minimum completion time for the project. (2 marks)

Path: B - C - E - G
MCT: 30 days

- (c) What is the minimum time that two people would take to complete all tasks if only one person can be allocated to each task at any one time? Justify your answer. (2 marks)

33 days.
Person A: Critical path (30 days)
Person B: A - D - F (33 days)

Question 9

(6 marks)

The worldwide consumption of coal (in billion tonnes of oil equivalent, BTOE) is shown in the graph below from 1965 until 2010. A billion is one thousand million.

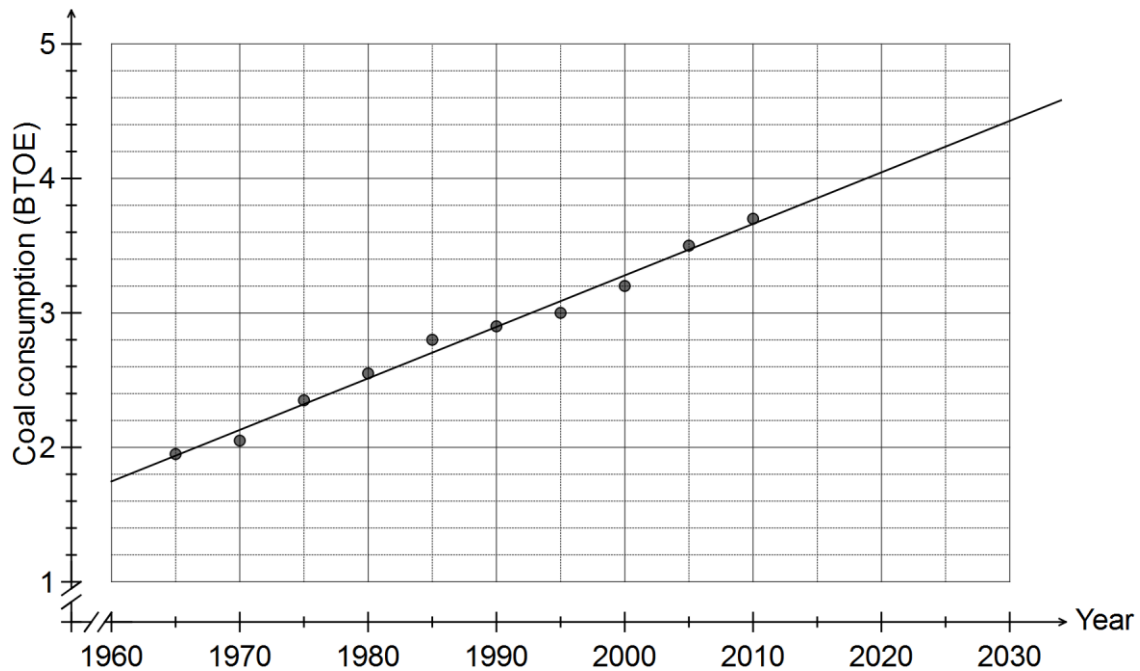

- (a) State the worldwide consumption of coal in 1985. (1 mark)

2.8 BTOE

- (b) The equation of the least squares line that models the relationship between the year (x) and coal consumption (y) is $y = 0.0383x - 73.3272$. Draw this line on the graph above. (2 marks)

Hint: Use the two points calculated in (c)

- (c) Calculate, to two decimal places, estimates for the worldwide consumption of coal in
- (i) 1960. (1 mark)

1.74 BTOE

- (ii) 2025. (1 mark)

4.23 BTOE

- (d) Which value in (c) is more reliable? Explain your reasoning. (1 mark)

The estimate for 1960 - it involves less extrapolation than for 2025.

Question 10

(8 marks)

A reducing balance loan can be modelled by $T_{n+1} = 1.0035T_n - 420$, $T_0 = 6500$, where T_n is the balance of the loan at the start of the n^{th} month. Interest is added to the loan at the end of each month, just before a repayment is made.

(a) State

(i) the initial loan amount.

(1 mark)

\$6 500

(ii) the regular monthly repayment.

(1 mark)

\$420

(iii) the monthly interest rate, as a percentage.

(1 mark)

0.35%

(b) The final loan repayment is less than the regular repayment. Determine the number of loan repayments and what the final repayment is.

(2 marks)

16 repayments.

 $420 - 25.60 = \$394.40$

 Final is \$394.40.

Compound Interest	
N	16
I%	4.2
PV	6500
PMT	-420
FV	25.60139548
P/Y	12
C/Y	12

(c) Calculate the total interest paid over the life of the loan.

(2 marks)

$15 \times 420 + 394.40 = 6694.40$

 $6694.40 - 6500 = \$194.40$

(d) Determine the monthly amount required to pay off the initial loan amount in 12 equal repayments.

(1 mark)

\$554.07

Compound Interest	
N	12
I%	4.2
PV	6500
PMT	-554.068515
FV	0
P/Y	12
C/Y	12

Question 11

(8 marks)

Data concerning the causes of alcohol-attributable hospitalisation from a sample of 338 young males and females is shown in the table below.

Cause	Males	Females
Assault	55	37
Fall	34	16
Road injury	31	13
Alcohol abuse	18	29
Other	43	62

A researcher plans to investigate whether causes of alcohol-attributable hospitalisation are associated with the gender of young people.

- (a) State the explanatory variable for the investigation. (1 mark)

Gender of young people.

- (b) Calculate the percentage of young people in the sample who were hospitalised for a road injury. (1 mark)

$$\frac{31 + 13}{338} = \frac{44}{338} \approx 13\%$$

- (c) Of the males, what percentage were hospitalised due to alcohol abuse. (1 mark)

$$\frac{18}{55 + 34 + 31 + 18 + 43} = \frac{18}{181} \approx 10\%$$

- (d) Construct an appropriately percentaged two-way table that can be used to help identify whether the cause of alcohol-attributable hospitalisation can be explained by the gender of young people. (3 marks)

Cause	Males	Females
Assault	30%	24%
Fall	19%	10%
Road injury	17%	8%
Alcohol abuse	10%	18%
Other	24%	40%
Total	100%	100%

- (e) Comment on whether the cause of alcohol-attributable hospitalisation can be explained by the gender of young people. (2 marks)

The cause of hospitalisation DOES appear to be associated with gender, as the percentage figures for males and females are very different for all causes.

Question 12

(9 marks)

A sculpture was sold for \$22 000 by an art gallery.

- (a) The sculpture could be bought on terms in which a premium of 8% was added to the purchase price and then the total amount repaid to the gallery in 12 equal monthly repayments. How much would each repayment be? (2 marks)

$$22000 \times 1.08 = 23760$$

$$23760 \div 12 = \$1980 \text{ per month}$$

- (b) The sculpture was expected to increase in value at an annual rate of 9%. What is the expected value of the sculpture three years after it was purchased, to the nearest one hundred dollars? (2 marks)

$$22000 \times 1.09^3 = \$28490.64$$

$$\approx \$28\ 500$$

- (c) An amount of \$22 000 can also be invested using two different saving schemes:

Scheme A, in which interest of 5.44% per annum is compounded monthly; and

Scheme B, in which interest of 5.46% per annum is compounded quarterly.

- (i) Calculate the effective interest rates of both schemes, correct to 4 decimal places, and hence state which scheme would pay the most interest over three years. (3 marks)

$$E_A = \left(1 + \frac{0.0544}{12}\right)^{12} = 1.055777$$

Rate is 5.5777% pa (4dp)

$$E_B = \left(1 + \frac{0.0546}{4}\right)^4 = 1.055728$$

Rate is 5.5728% pa (4dp)

Scheme A would pay the most interest.

- (ii) Calculate the interest that accrues over three years on \$22 000 with a rate of 5.45% per annum, compounded every four months. (2 marks)

$$22000 \left(1 + \frac{5.45}{3 \times 100}\right)^{3 \times 3} = 25869.77$$

$$25869.77 - 22000 = \$3\ 869.77$$

Question 13

(10 marks)

A parcel delivery service visits a rural town every Monday, Tuesday, Thursday and Friday in the period leading up to Christmas. The number of parcels delivered on each visit are shown below.

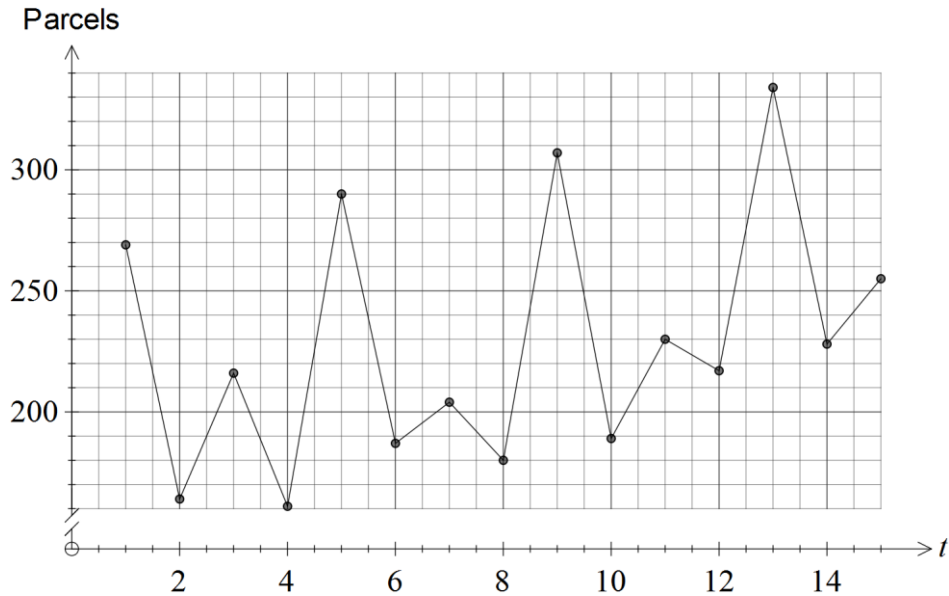

The table below shows the data for the second and third weeks of the delivery service.

Time (t)	Week	Day	Parcels delivered
4	1	Fri	
5	2	Mon	290
6	2	Tue	187
7	2	Thu	204
8	2	Fri	180
9	3	Mon	307
10	3	Tue	189
11	3	Thu	230
12	3	Fri	217
13	4	Mon	

(a) Which two days tend to be the quietest for the parcel delivery service each week? (1 mark)

Tuesday and Friday.

(b) What feature of the graph suggests that smoothing the data with a four-point centred moving average would be appropriate? (1 mark)

There is a repeating cycle to the graph every four points.

- (c) Calculate the four-point centred moving average for Friday of Week 2. (2 marks)

$$\frac{187 \div 2 + 204 + 180 + 307 + 189 \div 2}{4} = 219.75$$

The seasonal indices for Monday, Thursday and Friday are shown in the table below.

Day	Mon	Tue	Thu	Fri
Seasonal index	1.28		0.96	0.91

- (d) Determine the seasonal index for Tuesday. (1 mark)

$$4 - (1.28 + 0.96 + 0.91) = 0.85$$

- (e) Which day of Week 3 had the fewest number of parcels delivered when the deseasonalised figures are compared? Justify your answer. (3 marks)

$$307 \div 1.28 = 239.8$$

$$189 \div 0.85 = 222.4$$

Tuesday had the fewest parcels.

$$230 \div 0.96 = 239.6$$

$$217 \div 0.91 = 238.5$$

The regression model calculated from the data is $p = 4.45t + 185.5$, where p is the deseasonalised number of parcels delivered at time t .

- (f) Determine the best forecast for the actual number of parcels delivered on Friday of the fourth week. (2 marks)

$$p = 4.45(16) + 185.5$$

$$= 256.7$$

$$256.7 \times 0.91 = 233.6$$

$$\approx 234 \text{ parcels}$$

Question 14

(8 marks)

The table below shows the cost of building direct light rail links between seven different locations, in millions of dollars.

	A	B	C	D	E	F	G
A	-	50	58	-	-	54	35
B	50	-	44	65	32	33	58
C	58	44	-	42	43	-	-
D	-	65	42	-	45	68	-
E	-	32	43	45	-	32	61
F	54	33	-	68	32	-	49
G	35	58	-	-	61	49	-

- (a) Use Prim's algorithm to determine the minimum spanning tree for this network and clearly state the cost of building the minimum spanning tree. (4 marks)

Minimum spanning tree connects circled locations in table above.
Total cost is \$233 million.

- (b) Show the minimal spanning tree on the graph below. (2 marks)

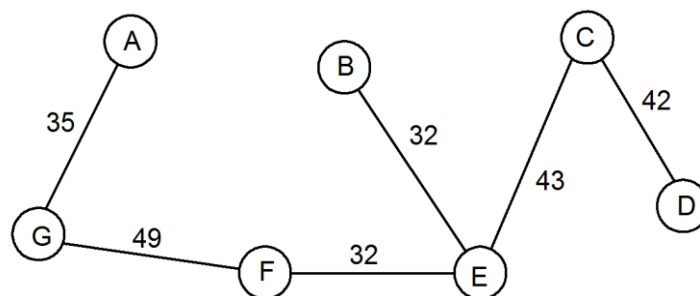

- (c) An option exists to use an existing railway line between locations A and F, making it possible to halve the cost of this link. If this option is taken, describe the effect, if any, on the cost of building the minimal spanning tree. (2 marks)

Link AF now costs \$27 m and so replaces link GF, saving \$22 m.

Question 15

(8 marks)

A builder is using a machine to drive 5 m long steel piles into the ground as part of the foundations for an apartment block. The first hit of the machine drives the steel pile 75 cm into the ground. The second hit drives it another 60 cm into the ground and each subsequent hit drives the pile 80% of the distance of the previous hit into the ground.

- (a) Determine the distances the steel pile moves into the ground on the third and fourth hits. (2 marks)

$$60 \times 0.8 = 48 \text{ cm}$$

$$48 \times 0.8 = 38.4 \text{ cm}$$

- (b) State a rule for the distance the steel pile moves into the ground on the n^{th} hit. (2 marks)

$$T_n = 75(0.8)^{n-1}$$

- (c) After five hits, calculate the total distance that the pile has been driven into the ground. (2 marks)

$$T_5 = 30.72$$

$$75 + 60 + 48 + 38.4 + 30.72 = 252.12 \text{ cm}$$

- (d) On which hit does the steel pile first move less than 1 cm into the ground? Justify your answer. (2 marks)

$$T_{20} = 1.0809$$

$$T_{21} = 0.8647$$

On the 21st hit.

Question 16

(8 marks)

Waste is moved through a treatment facility from the receiving dock R to transfer station S. The weighted graph below shows the pipes that waste can flow through, with the number on each edge representing the maximum amount of waste, in tonnes per hour, which can be moved along that pipe.

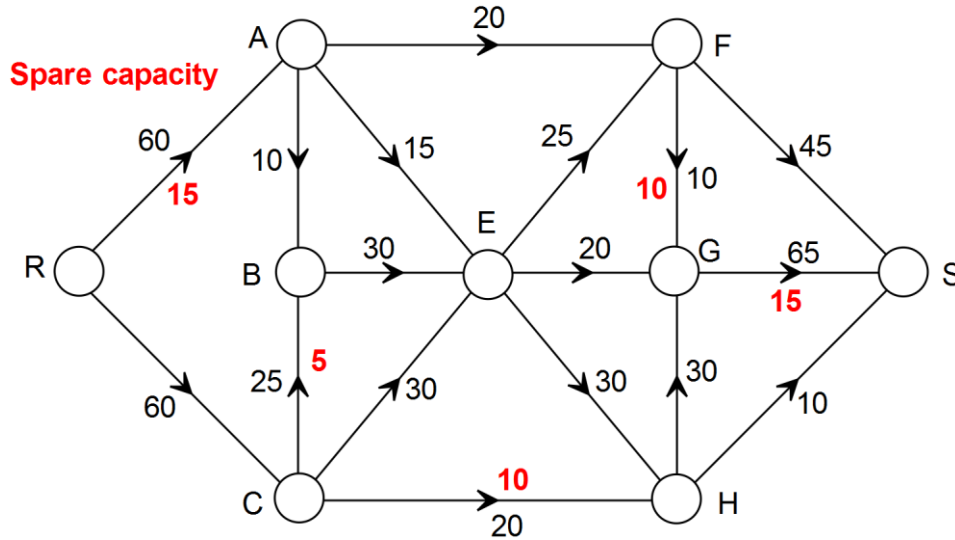

- (a) What is the maximum hourly amount of waste that can be moved from the receiving dock to the transfer station? To obtain full marks, you must show systematic working. (5 marks)

$R A F S = 20$
 $R A E F S = 15$
 $R A B E F S = 10$
 $R C B E G S = 20$
 $R C E H G S = 30$
 $R C H S = 10$
 Total 105 tonnes per hour.

- (b) Engineers have identified one pipe that could be closed for maintenance without affecting the maximum hourly flow through the facility. State which pipe this is. (1 mark)

Pipe from F to G.

- (c) The pipe from A to F is to be upgraded to increase the amount of waste that can flow through it and hence increase the flow through the facility. Determine the largest possible increase in the maximum hourly flow through the facility after the upgrade is complete. (2 marks)

A copy of the graph is shown below for your use, if required.

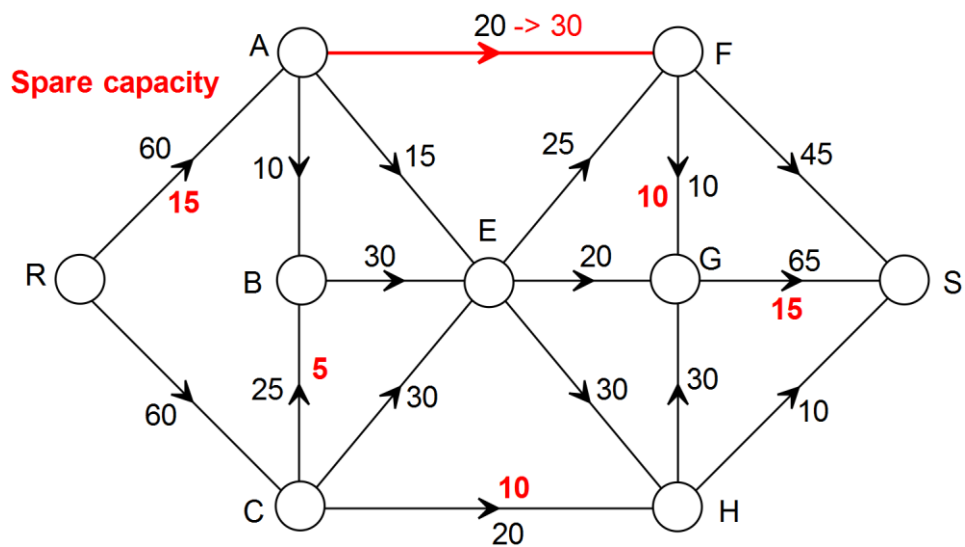

Maximum possible increase is 10 tonnes per hour.
This can flow along R A F G S.

Question 17

(9 marks)

A fish farm is stocked with 5000 fish. The owners plan to sell 25% of the fish stock throughout the year and then to re-stock the farm with an extra 300 fish at the end of the year.

The fish stock, F_n , at the start of year n can be modelled by $F_{n+1} = 0.75F_n + 300$, $F_0 = 5000$.

- (a) Explain the significance of the 0.75 in the model. (1 mark)

Owners sell 25% of stock, so 75% will be left at end of year - hence 0.75 multiplier.

- (b) Complete the table below for the first 8 years, rounding values to the nearest ten. (2 marks)

n	0	1	2	3	4	5	6	7	8
F_n	5000	4050	3340	2800	2400	2100	1880	1710	1580

- (c) Graph the fish stock at the start of the first 8 years on the axes below. (3 marks)

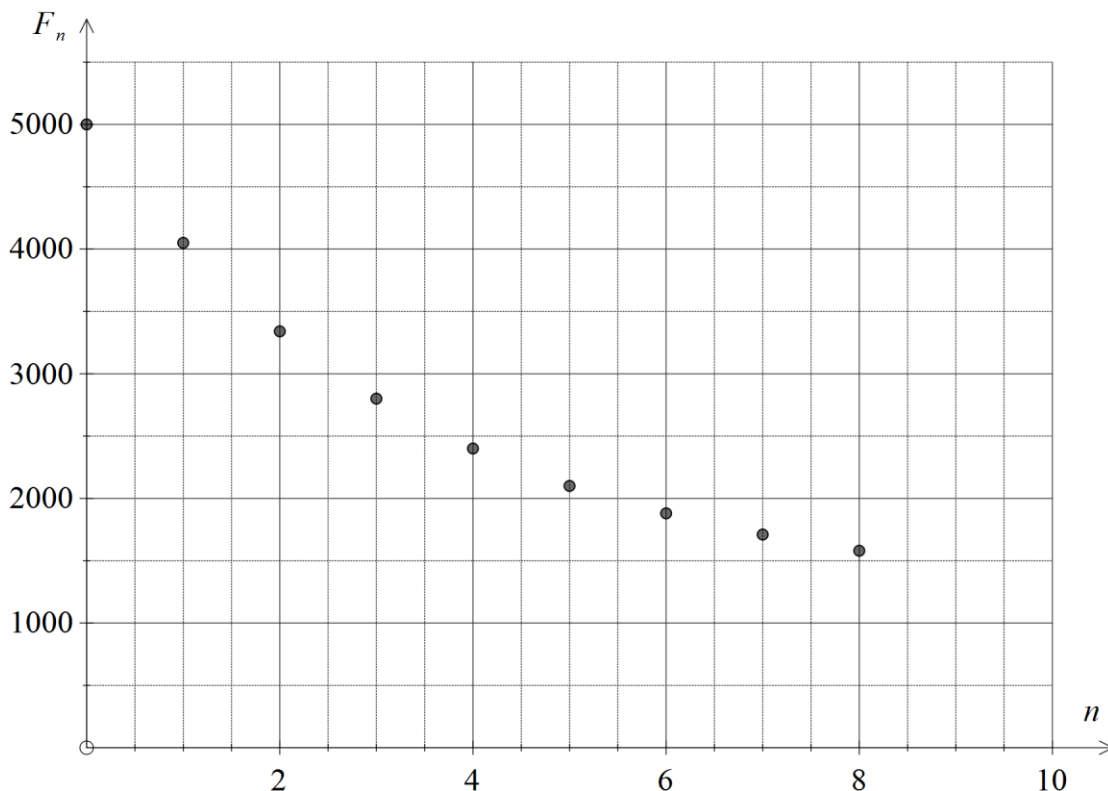

- (d) Comment on how the size of the fish stock is changing over the first 8 years. (1 mark)

Decreasing, but at a slower and slower rate. (Decreasing at a decreasing rate).

- (e) Calculate the expected fish stock after 20 years, and comment on the long-term size of the fish stock according to this model. (2 marks)

$$F_{20} = 1212$$

The size of the fish stock will reach a steady state of 1200 fish, after about 30 years.

Question 18

(11 marks)

A small facility within a hospital operates three shifts each day. The numbers of patients treated per shift over a four day period are shown in the graph and table below.

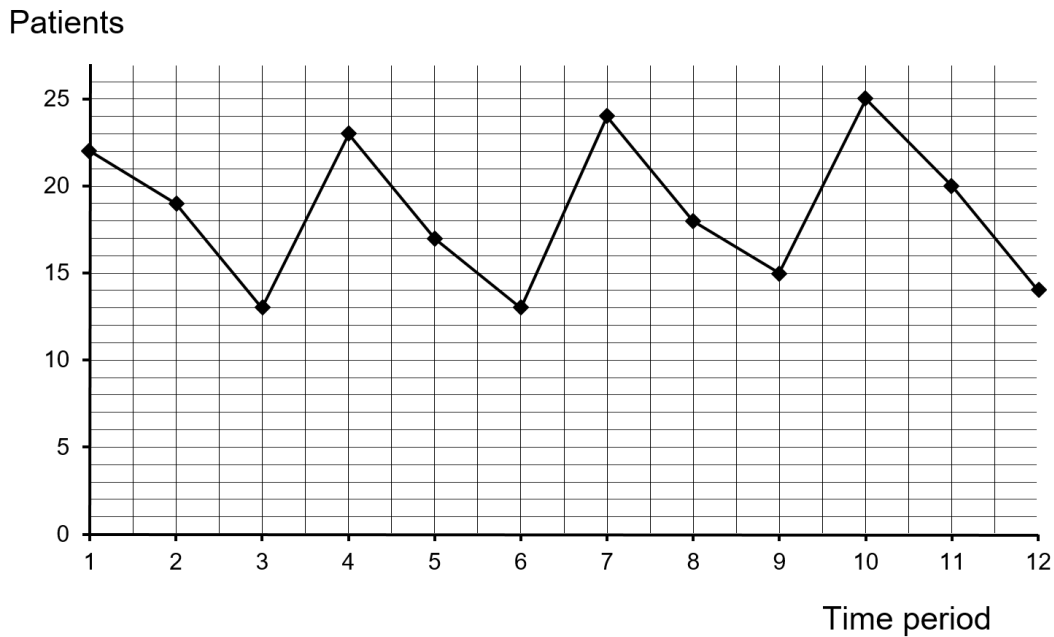

Day	Shift	Time period (<i>t</i>)	Number of patients	Daily mean	Percent of daily mean	Deseasonalised patients (<i>n</i>)
Mon	A	1	22	P	122%	17.4
	B	2	19		106%	19.0
	C	3	13		72%	17.6
Tue	A	4	23	17.7	130%	18.2
	B	5	17		96%	17.0
	C	6	13		74%	17.6
Wed	A	7	Q	19.0	126%	19.0
	B	8	18		95%	18.0
	C	9	15		79%	20.3
Thu	A	10	25	19.7	R	19.8
	B	11	20		102%	20.1
	C	12	14		71%	18.9

(a) Comment on the trend and seasonality displayed in the time series plot. (2 marks)

A slight increasing trend over the 12 shifts, with a clear seasonal pattern within each day, where the number of patients treated decreases from shift A to shift C.

The table also contains columns used to deseasonalise the time series using the average percentage method.

- (b) Calculate the values of the entries P, Q and R in the table. (3 marks)

$$P = \frac{22+19+13}{3} = 18$$

$$\frac{Q+18+15}{3} = 19 \Rightarrow Q = 24$$

$$R = \frac{25}{19.7} \times 100 = 127\%$$

- (c) Show all steps required to calculate that the deseasonalised number of patients shown in the table for shift C on Wednesday is 20.3. (2 marks)

Calculate seasonal index for shift C:

$$\frac{72+74+79+71}{4} = 74\%$$

Deseasonalise figure using index:

$$15 \div 0.74 = 20.3$$

- (d) Determine the least-squares regression line to model the relationship between the time period, t , and the deseasonalised number of patients, n , in the table. (2 marks)

$$n = 0.1983t + 17.286$$

- (e) Use the regression line, and making seasonal adjustments as necessary, to forecast the number of patients treated during shift C on Friday, when $t = 15$. (2 marks)

$$n = 0.1983(15) + 17.286$$

$$= 20.26$$

$$20.26 \times 0.74 = 14.99 \approx 15 \text{ patients}$$

Question 19

(8 marks)

A parent won \$360 000 in a competition and decided to use it to set up a perpetuity for his two children. The money is invested in an account at 4.8% per annum interest, compounded monthly.

- (a) Determine how much the perpetuity would pay each child every month. (2 marks)

$$Q = \frac{360000}{100 \times (4.8 \div 12)} = 1440$$

$$1440 \div 2 = 720 \text{ per child}$$

- (b) If instead the parent opted for an annuity of \$2 100 per month from the same account for each child, determine how much each would receive in total, up to the time when the balance of the account first falls below \$1000. (3 marks)

$$2 \times 2100 = 4200$$

105 payments

$$105 \times 2100 = \$220\,500 \text{ per child}$$

Compound Interest	
N	105
I%	4.8
PV	-360000
PMT	4200
FV	725.9418077
P/Y	12
C/Y	12

- (c) One of the children asked if they could have \$40 000 from their half-share to buy a car and then receive the remainder as equal monthly payments from the annuity over five years. How much would this child receive in total? (3 marks)

$$180000 - 40000 = 140000$$

$$2629.16 \times 60 = 157749.60$$

$$157749.60 + 40000 = \$197\,749.60$$

Compound Interest	
N	60
I%	4.8
PV	-140000
PMT	2629.163881
FV	0
P/Y	12
C/Y	12

Additional working space

Question number: _____

© 2016 WA Exam Papers. Rossmoyne Senior High School has a non-exclusive licence to copy and communicate this paper for non-commercial, educational use within the school.
No other copying, communication or use is permitted without the express written permission of WA Exam Papers.